

Fiche technique produit
Lavabo 950.11.601

HEWI



Lavabo 950.11.601

- en fonte minérale avec surface non poreuse, blanc alpin
- avec tablette et vasque ovale
- système d'appui intégré, utilisable comme porte-serviettes
- sans trop-plein
- pour robinetterie à un trou
- accessible aux chaises roulantes conformément aux normes DIN 18040 et ÖNORM B1600/1601
- charge admissible selon EN 14688
- largeur 850 mm, profondeur 550 mm
- fixation par vis à suspension
- caractérisation CE selon les produits de construction règlement no. 305/2010 CE



Dimensions en mm

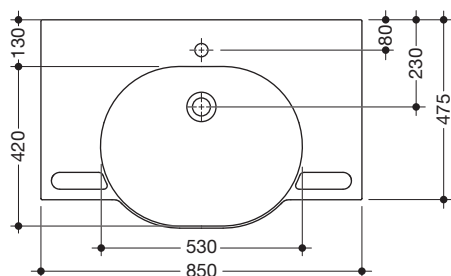
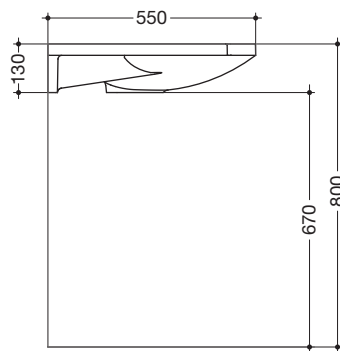
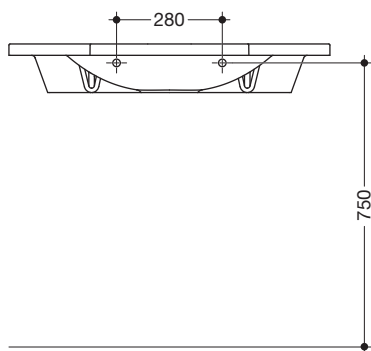

Sous réserve de toute modification technique, 04.11.2014

HEWI Heinrich Wilke GmbH
Postfach 1260
D-34442 Bad Arolsen

Tél: +49 5691 82 478
Fax: +49 5691 82 99 478
international@hewi.com
www.hewi.com

HEWI France
217, cours Lafayette
F-69006 Lyon

Tél: +33 4 72 83 09 09
Fax: +33 4 72 83 09 00
contact@hewi.fr
www.hewi.fr